

- ▶ Full speed 256 Kbytes program FLASH, 20 Kbytes SRAM with 2 Kbytes DMA buffer and on-board 128 bytes serial EEPROM
- ▶ Heavy duty 3 Amp power regulation
- ▶ Choice of 8 or 16 buffered Analog I/O with 12-Bit A/D
- ▶ 8 PWM Output Channels
- ▶ Up to 56 Digital I/O with optional jumper selectable 3.3/5V Pull Ups
- ▶ Dual UART with TTL or software selectable RS-232/RS-485 communications
- ▶ Dual SPI (4 chip selects) and Dual I2C interfaces
- ▶ Dual on-board CanBUS (DeviceNet) drivers
- ▶ Dual Port RAM and DMA
- ▶ External CPU Reset and External Device Reset
- ▶ -40 to +85°C industrial components with optional High-Reliability version
- ▶ Credit Card format with dual 50 pin (0.1" x 2 standard) headers
- ▶ Microchip's CodeGuard™ Security for Embedded Intellectual Property protection
- ▶ Fully compatible with all Microchip based software development tools
- ▶ Production licenses available for high volumes

M2M

Industrial Automation

Instrumentation

Advanced Energy Management

Wireless Devices

Data Collection & Logging

Asset Management

Security Systems

dsCORE E8100

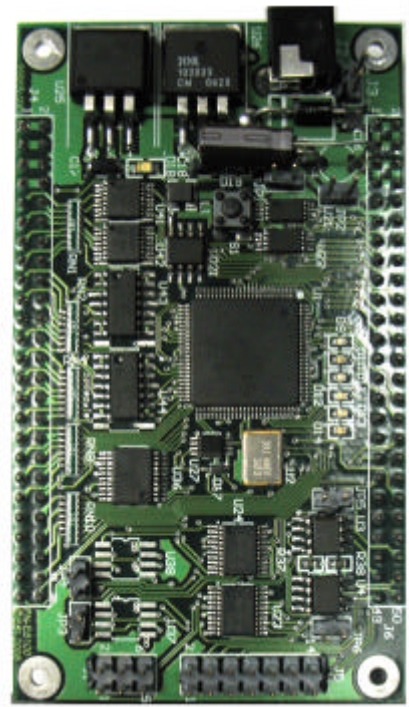

(Actual Size)

The dsCORE family of Embedded Digital Signal Controllers are intended for demanding, high-performance device control and intelligence applications. Based on the **Microchip dsPIC33F** 16-bit DSC (0-40 MIPS), the E8100 delivers exceptional processing power, performance features and versatility—all in a package the size of a business card.

With a full complement of I/O, the E8100 is ideal for product integration in a variety of applications. As a design building block, the E8100 shortens product development cycles and accelerates time-to-market by reducing design risk to zero.

With all the necessary interface drivers, power regulators and buffered I/O provided, connecting the E8100 to virtually any peripheral technology is a one step process.

Microchip's rich software support for the dsPIC line also eases integration of the 8100 into your product designs by streamlining code development.

Embedded Sense, Inc.
2145 Meadowpine Blvd., Mississauga,
Ontario, L5N 6R8 Canada
Tel: 1 905 286 1750
Fax: 1 905 286 9470
info@embeddedsense.com

EMBEDDED
Sense

www.embeddedsense.com

dsCORE 8100 Specifications

FUNCTIONAL

CPU:	dsPIC33FJ256GP710, DC-40MHz
FLASH / EEPROM:	256 Kbytes / 128 byte
RAM:	30 KBytes
Analog Inputs:	Available configurations of 0, 4, 8, 12 or 16 Buffered Inputs (8, 12, 16, 20 or 24 Un-Buffered Inputs)
PWM Outputs:	8 max.
Digital I/O:	57 Inputs/41, 45, 49, 53, or 57 Outputs (Depending on Analog Input Configuration)
Peripherals:	2 x SPI (max.), 2 x I2C (max.), 2 x CAN
Communications:	TTL or selectable RS-232/RS-485 (2 Ports max.)

ELECTRICAL

Operating Voltage:	5 - 12 VDC
Power Consumption:	Operating (No I/O Loading) 38 mA (typical)

MECHANICAL

Dimensions:	2.0 x 3.5 x 0.9 in. (5.1 x 8.9 x 2.29 cm.)
Top Clearance:	.33 in (0.84 cm.)
Bottom Clearance:	.33 in (0.84 cm.)
Connectors:	0.025 Dia. Header Pin, 0.100 Spacing

ENVIRONMENTAL

Operating / Storage:	-25 to +85 °C
	95% Humidity (Non-Condensing)
High Reliability Option:	-40 to +85 °C, 100% Humidity Conformal Coated 100% Burn-In & Temperature Testing

SOFTWARE TOOLS

- 100% compatible with MPLAB® Integrated Development Environment, MPLAB® C30, Embedded Workbench and dsPIC C Compilers.
- 100% compatible with the complete line of Microchip provided Software Libraries and Application Development Tools including Symmetric and Asymmetric Key Embedded Encryption Libraries.
- Ships with Pre-Installed Embedded Sense boot loader on UART#2.
- In-circuit debug (ICD) and In-circuit serial programming (ICSP) supported through 2 x 3 header.

OPERATING SYSTEMS

- 100% compatible with CMX Systems, Inc. CMX-Scheduler™.
- 100% compatible with CMX Systems, Inc. CMX-Tiny+™ and CMX-RTX+™ OS
- 100% compatible with OSEK/VDX v2.2 from Vector Informatik, GmbH

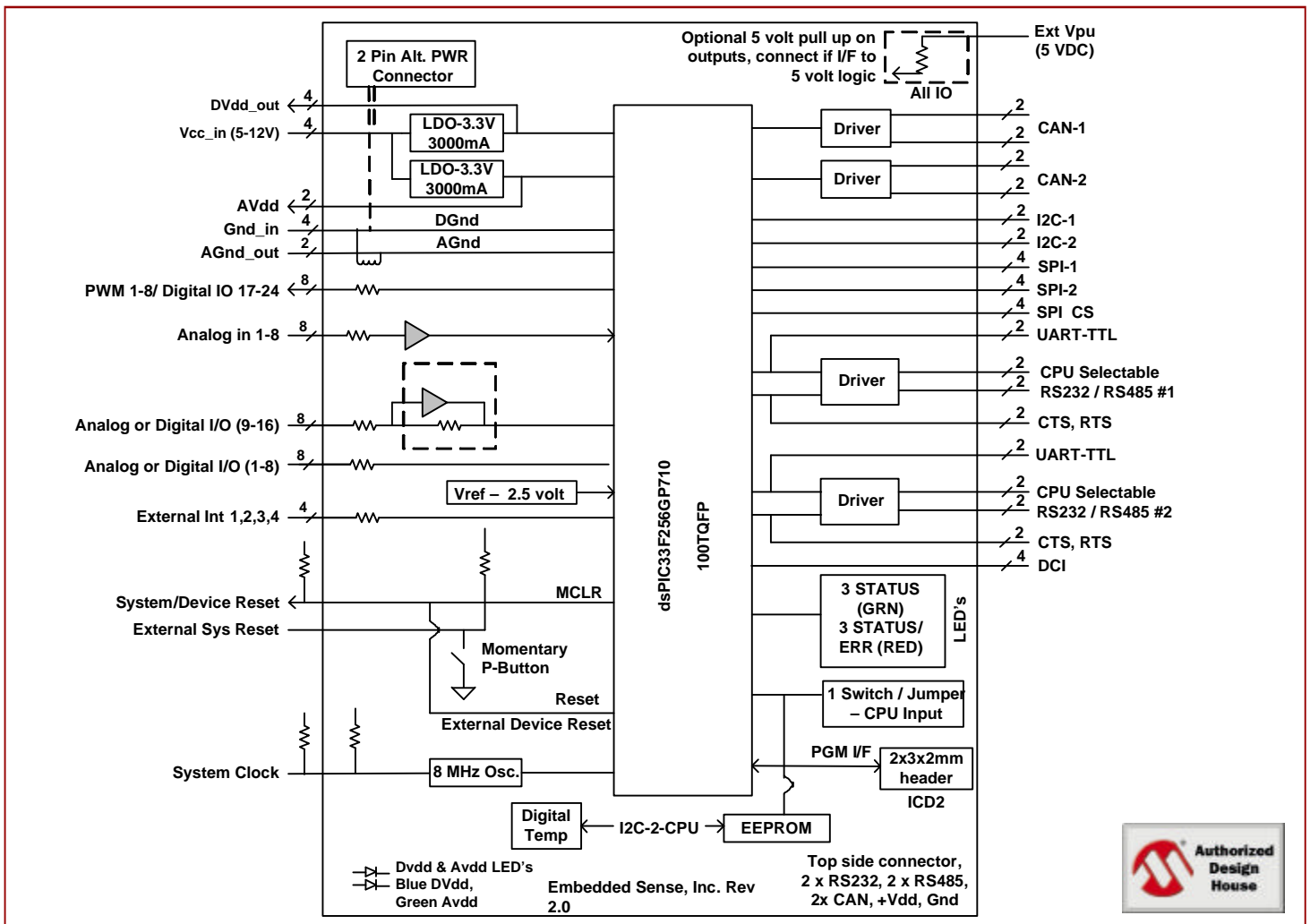

Embedded Sense, Inc.
2145 Meadowpine Blvd., Mississauga,
Ontario, L5N 6R8 Canada

Tel: 1 905 286 1750
Fax: 1 905 286 9470
info@embeddedsense.com

Copyright © 2006 Embedded Sense Inc.
All trademarks are the property of their respective owners.
Specifications are Preliminary and subject to change without notice.
Designed and printed in Canada.